

- Complies with SPI-2 and SPI-3 Standards
- 2.75-V to 7-V Operation
- 1.8-pF Channel Capacitance during Disconnect
- 1- $\mu$ A Supply Current in Disconnect Mode
- 110- $\Omega$ /2.5-k Programmable Termination
- Completely Meets SCSI Hot Plugging
- -650-mA Sourcing Current for Termination
- +400-mA Sinking Current for Active Negation Drivers
- Trimmed Termination Current to 4%
- Trimmed Impedance to 7%
- Current Limit and Thermal Shutdown Protection

## description

The UCC5611 provides 18 lines of active termination for a SCSI (Small Computer Systems Interface) parallel bus. The SCSI standard recommends active termination at both ends of the cable segment.

The UCC5611 is ideal for high performance 3.3-V SCSI systems. The key features contributing to such low-operating voltage are the 0.1-V drop-out regulator and the 2.75-V reference. During disconnect the supply current is typically only 1  $\mu$ A, which makes the IC attractive for battery powered systems.

The UCC5611 is designed with an ultra-low channel capacitance of 1.8 pF, which eliminates effects on signal integrity from disconnected terminators at interim points on the bus.

The UCC5611 can be programmed for either a 110- $\Omega$  or 2.5-k $\Omega$  termination. The 110- $\Omega$  termination is used for standard SCSI bus lengths and the 2.5-k $\Omega$  termination is typically used in short bus applications. When driving the TTL compatible  $\overline{\text{DISCNCT}}$  pin directly, the 110- $\Omega$  termination is connected when the  $\overline{\text{DISCNCT}}$  pin is driven high, and disconnected when low. When the  $\overline{\text{DISCNCT}}$  pin is driven through an impedance between 80 k $\Omega$  and 150 k $\Omega$ , the 2.5-k $\Omega$  termination is connected when the  $\overline{\text{DISCNCT}}$  pin is driven high, and disconnected when driven low.

## block diagram

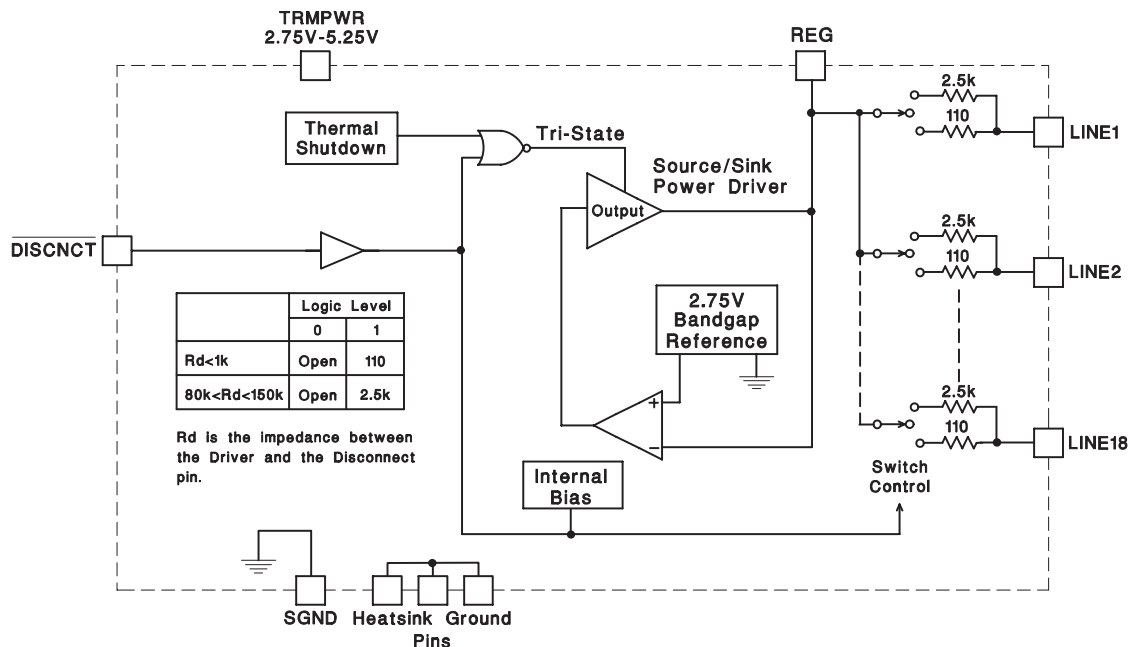

UDG-94131-1



Please be aware that an important notice concerning availability, standard warranty, and use in critical applications of Texas Instruments semiconductor products and disclaimers thereto appears at the end of this data sheet.

# UCC5611

## 18-LINE 3-5 VOLT SCSI ACTIVE TERMINATOR, REVERSE DISCONNECT

SLUS348A – MARCH 1997 – REVISED NOVEMBER 2000

### description (continued)

The power amplifier output stage allows the UCC5611 to source full termination current and sink active negation current when all termination lines are actively negated.

The UCC5611 is pin for pin compatible with Texas Instrument's other 18-line SCSI terminators, except that  $\overline{\text{DISCNCT}}$  is now active low, allowing lower capacitance and lower voltage upgrades to existing systems. The UCC5611, as with all of Texas Instrument terminators, is completely hot pluggable and appears as high impedance at the terminating channels with  $V_{\text{TRMPWR}} = 0 \text{ V}$  or open.

Internal circuit trimming is utilized, first to trim the 110- $\Omega$  termination impedance to a 7% tolerance, and then most importantly, to trim the output current to a 4% tolerance, which maximizes noise margin.

Other features include thermal shutdown and current limit.

This device is offered in low thermal resistance versions of the industry standard 28-pin wide body SOIC and 28-pin PLCC.

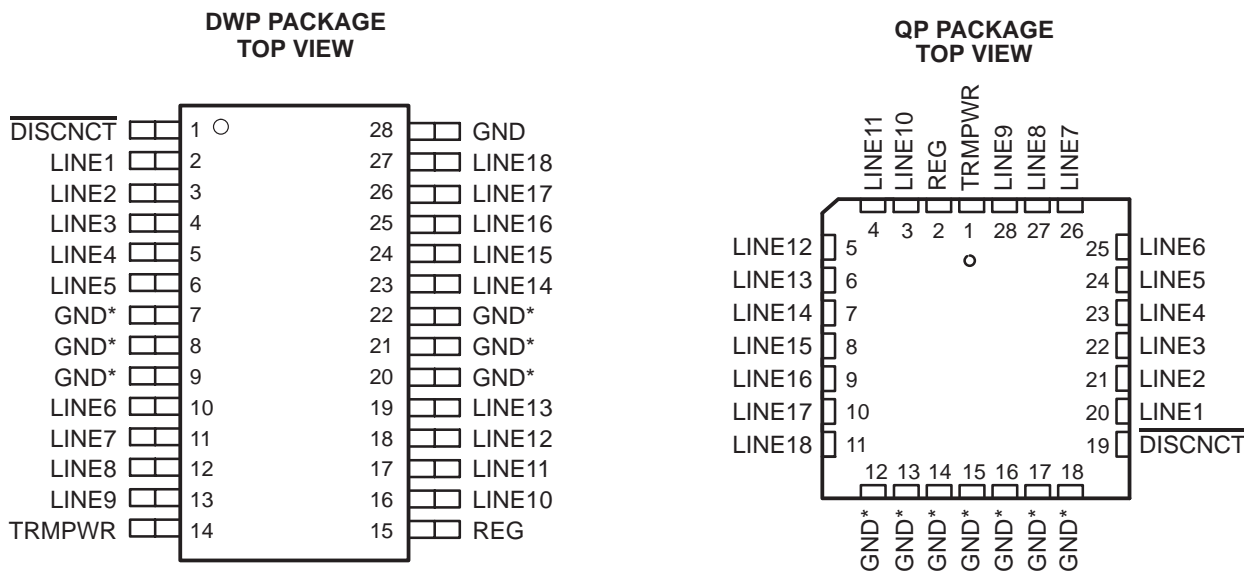

\* DWP package pin 28 serves as signal ground; pins 7, 8, 9, 20, 21, 22 serve as heatsink/ground.

\* QP package pins 12-18 serve as both heatsink and signal ground.

### AVAILABLE OPTIONS

T <sub>J</sub>	PACKAGED DEVICES†	
	SOIC (DWP)	PLCC (QP)
0°C to 70°C	UCC5611DWP	UCC5611QP

† Available tape and reeled. Add TR suffix to device type to order quantities of 1000 devices per reel.



# UCC5611

## 18-LINE 3-5 VOLT SCSI ACTIVE TERMINATOR, REVERSE DISCONNECT

SLUS348A – MARCH 1997 – REVISED NOVEMBER 2000

### absolute maximum ratings over operating free-air temperature (unless otherwise noted)<sup>†‡</sup>

Tempwr voltage	7 V
Signal line voltage	0 V to 7 V
Regulator output current	Self-regulating
Storage temperature, T <sub>stg</sub>	-65°C to 150°C
Operating junction temperature, T <sub>J</sub>	-55°C to 150°C
Lead temperature (soldering, 10 Sec.)	300°C

<sup>†</sup> Stresses beyond those listed under “absolute maximum ratings” may cause permanent damage to the device. These are stress ratings only, and functional operation of the device at these or any other conditions beyond those indicated under “recommended operating conditions” is not implied. Exposure to absolute-maximum-rated conditions for extended periods may affect device reliability.

<sup>‡</sup> Unless otherwise specified all voltages are with respect to Ground. Currents are positive into, negative out of the specified terminal. Consult Packaging Section of Interface Products Data Book (TI Literature Number SLUD002) for thermal limitations and considerations of packages.

### recommended operating conditions

Tempwr voltage	2.75 V to 5.25 V
Signal line voltage	0 V to 5 V
Disconnect input voltage	0 V to Tempwr

### electrical characteristics, these specifications apply for T<sub>A</sub> = 0°C to 70°C. TRMPWR = 3.3 V, DISCNCT = 3.3 V, R<sub>DISCNCT</sub> = 0 Ω. T<sub>A</sub> = T<sub>J</sub>, (unless otherwise stated)

PARAMETER	TEST CONDITIONS	MIN	TYP	MAX	UNITS
<b>Supply Current Section</b>					
Tempwr supply current	All termination lines = open		1	2	mA
	All termination lines = 0.2 V		415	435	mA
Power down mode	DISCNCT = 0V		0.5	5	μA
<b>Output Section (110 Ω – Terminator Lines)</b>					
Terminator impedance	See Note 4	102.3	110	117.7	Ω
Output high voltage	TRMPWR = 3 V, See Note 1	2.5	2.7	3.0	V
Max output current	V <sub>LINE</sub> = 0.2 V, T <sub>J</sub> = 25°C	-25.4	-23	-22.1	mA
	V <sub>LINE</sub> = 0.2 V	-25.4	-23	-21	mA
	V <sub>LINE</sub> = 0.2 V, TRMPWR = 3 V, T <sub>J</sub> = 25°C, See Note 1	-25.4	-23	-20.2	mA
	V <sub>LINE</sub> = 0.2 V, TRMPWR = 3 V, See Note 1	-25.4	-23	-19	mA
	V <sub>LINE</sub> = 0.5 V			-22.4	mA
Output leakage	DISCNCT = 0 V, TRMPWR = 0 V to 5.25 V		10	400	nA
Output capacitance	DISCNCT = 0 V, DWP package, See Note 2, See Note 3		1.8	2.5	pF
<b>Output Section (2.5 kΩ – Terminator Lines) (R<sub>DISCNCT</sub> = 80 kΩ)</b>					
Terminator impedance		2	2.5	3	kΩ
Output high voltage	TRMPWR = 3 V, See Note 1	2.5	2.7	3.0	V
Max output current	V <sub>LINE</sub> = 0.2 V	-1.4	-1	-0.7	mA
	V <sub>LINE</sub> = 0.2 V, TRMPWR = 3 V, See Note 1	-1.5	-1	-0.6	mA
Output leakage	DISCNCT = 0 V, TRMPWR = 0 to 5.25 V		10	400	nA
Output capacitance	DISCNCT = 0 V, DWP package, See Note 2, See Note 3		1.8	2.5	pF

- NOTES: 1. Measuring each termination line while other 17 are low (0.2 V).  
 2. Ensured by design. Not production tested.  
 3. Output capacitance is measured at 0.5 V.  
 4. Tested by measuring I<sub>OUT</sub> with V<sub>OUT</sub> = 0.2 V and V<sub>OUT</sub> = V<sub>REG</sub> - 0.1 V then calculating the impedance.



# UCC5611

## 18-LINE 3-5 VOLT SCSI ACTIVE TERMINATOR, REVERSE DISCONNECT

SLUS348A – MARCH 1997 – REVISED NOVEMBER 2000

electrical characteristics, these specifications apply for  $T_A = 0^\circ\text{C}$  to  $70^\circ\text{C}$ .  $\text{TRMPWR} = 3.3\text{ V}$ ,  $\text{DISCNCT} = 3.3\text{ V}$ ,  $R_{\text{DISCNCT}} = 0\ \Omega$ .  $T_A = T_J$ , (unless otherwise stated)

PARAMETER	TEST CONDITIONS	MIN	TYP	MAX	UNITS
<b>Regulator Section</b>					
Regulator output voltage	$5.25\text{ V} > \text{TRMPWR} > 3\text{ V}$	2.5	2.7	3.0	V
Drop out voltage	All termination lines = $0.2\text{ V}$		0.1	0.2	V
Short circuit current	$V_{\text{REG}} = 0\text{ V}$	-800	-650	-450	mA
Sinking current capability	$V_{\text{REG}} = 3\text{ V}$	200	400	800	mA
Thermal shutdown	See Note 2		170		$^\circ\text{C}$
Thermal shutdown hysteresis	See Note 2		10		$^\circ\text{C}$
<b>Disconnect Section</b>					
Disconnect threshold	$R_{\text{DISCNCT}} = 0\ \& 80\ \text{k}\Omega$	0.8	1.5	2.0	V
Input current	$\text{DISCNCT} = 3.3\text{ V}$		30	50	$\mu\text{A}$

NOTES: 2. Ensured by design. Not production tested.

### APPLICATION INFORMATION

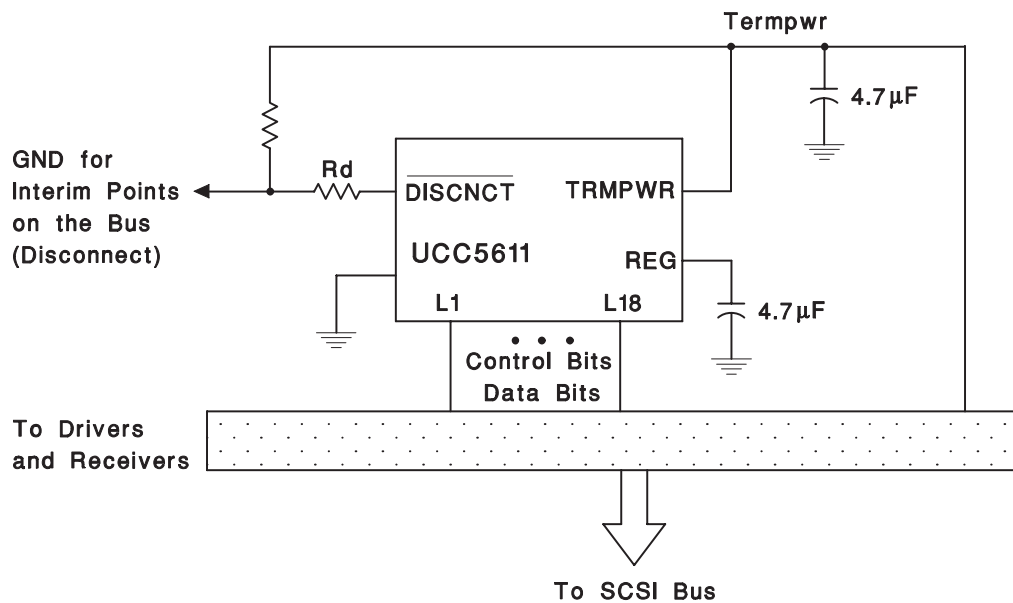

UDG-94132

Figure 1. Typical SCSI Bus Configurations Utilizing a UCC5611 Device

## IMPORTANT NOTICE

Texas Instruments Incorporated and its subsidiaries (TI) reserve the right to make corrections, modifications, enhancements, improvements, and other changes to its products and services at any time and to discontinue any product or service without notice. Customers should obtain the latest relevant information before placing orders and should verify that such information is current and complete. All products are sold subject to TI's terms and conditions of sale supplied at the time of order acknowledgment.

TI warrants performance of its hardware products to the specifications applicable at the time of sale in accordance with TI's standard warranty. Testing and other quality control techniques are used to the extent TI deems necessary to support this warranty. Except where mandated by government requirements, testing of all parameters of each product is not necessarily performed.

TI assumes no liability for applications assistance or customer product design. Customers are responsible for their products and applications using TI components. To minimize the risks associated with customer products and applications, customers should provide adequate design and operating safeguards.

TI does not warrant or represent that any license, either express or implied, is granted under any TI patent right, copyright, mask work right, or other TI intellectual property right relating to any combination, machine, or process in which TI products or services are used. Information published by TI regarding third-party products or services does not constitute a license from TI to use such products or services or a warranty or endorsement thereof. Use of such information may require a license from a third party under the patents or other intellectual property of the third party, or a license from TI under the patents or other intellectual property of TI.

Reproduction of information in TI data books or data sheets is permissible only if reproduction is without alteration and is accompanied by all associated warranties, conditions, limitations, and notices. Reproduction of this information with alteration is an unfair and deceptive business practice. TI is not responsible or liable for such altered documentation.

Resale of TI products or services with statements different from or beyond the parameters stated by TI for that product or service voids all express and any implied warranties for the associated TI product or service and is an unfair and deceptive business practice. TI is not responsible or liable for any such statements.

Following are URLs where you can obtain information on other Texas Instruments products and application solutions:

### Products

Amplifiers	<a href="http://amplifier.ti.com">amplifier.ti.com</a>
Data Converters	<a href="http://dataconverter.ti.com">dataconverter.ti.com</a>
DSP	<a href="http://dsp.ti.com">dsp.ti.com</a>
Interface	<a href="http://interface.ti.com">interface.ti.com</a>
Logic	<a href="http://logic.ti.com">logic.ti.com</a>
Power Mgmt	<a href="http://power.ti.com">power.ti.com</a>
Microcontrollers	<a href="http://microcontroller.ti.com">microcontroller.ti.com</a>
Low Power Wireless	<a href="http://www.ti.com/lpw">www.ti.com/lpw</a>

### Applications

Audio	<a href="http://www.ti.com/audio">www.ti.com/audio</a>
Automotive	<a href="http://www.ti.com/automotive">www.ti.com/automotive</a>
Broadband	<a href="http://www.ti.com/broadband">www.ti.com/broadband</a>
Digital Control	<a href="http://www.ti.com/digitalcontrol">www.ti.com/digitalcontrol</a>
Military	<a href="http://www.ti.com/military">www.ti.com/military</a>
Optical Networking	<a href="http://www.ti.com/opticalnetwork">www.ti.com/opticalnetwork</a>
Security	<a href="http://www.ti.com/security">www.ti.com/security</a>
Telephony	<a href="http://www.ti.com/telephony">www.ti.com/telephony</a>
Video & Imaging	<a href="http://www.ti.com/video">www.ti.com/video</a>
Wireless	<a href="http://www.ti.com/wireless">www.ti.com/wireless</a>

Mailing Address: Texas Instruments  
Post Office Box 655303 Dallas, Texas 75265